

Packaging - Specification ECOBULK



Transportcontainer ECOBULK 275 gal.
MX275 UN Nat/6"R TP 2"solid + sealc.red
Bfly 50 00 Cam 1PCA/Plast skid
2-Plt XL:XL
w/print "45326"

Schuetz Container Systems Inc.
200 Aspen Hill Road
NORTH BRANCH NJ 08876
USA

Article-No. 4052749

Date Jul 15, 2025
Page 1 / 4

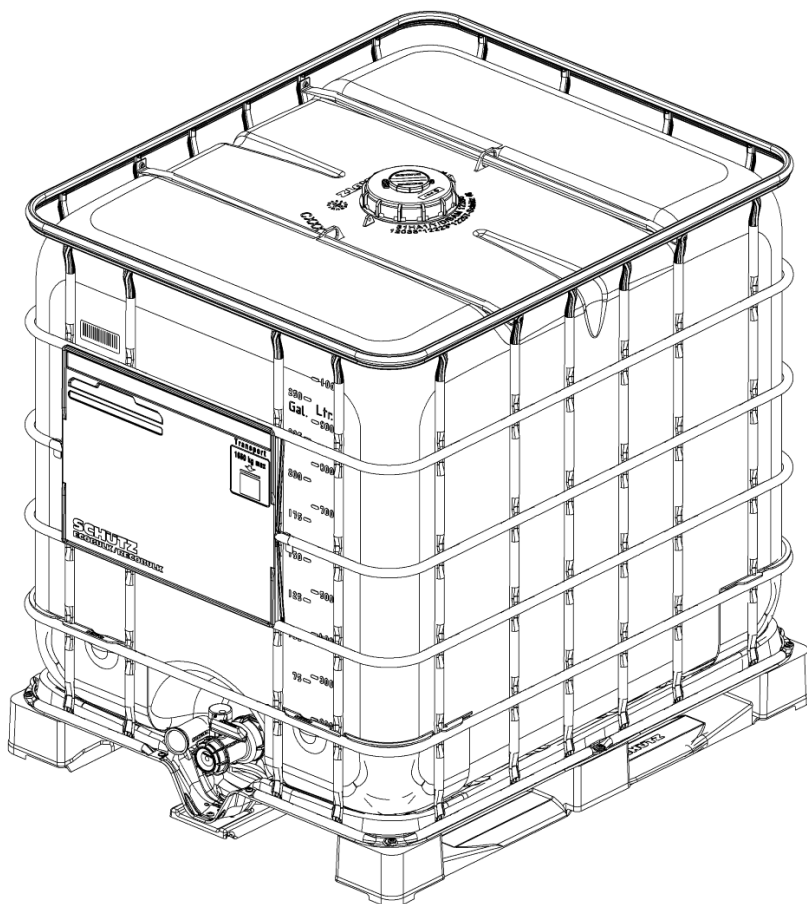

These pictures are for illustration purposes only and do not necessarily correspond to the specified products.

Weights and measures

Nominal Capacity	1.000 l	275 gal US
Brimful Capacity	1.060 l	280.027 gal US
Length	1.200 mm	47.240 in
Width	1.000 mm	39.370 in
Height with pallet	1.160 mm	45.670 in
Weight total approx	59.1 kg	130.2 lbs US

Pallet

Pallet type	Plastic-skidpallet
Opening height	min. 90mm, 4-way entry

Outer container

Packaging - Specification

ECOBULK



Transportcontainer ECOBULK 275 gal.
 MX275 UN Nat/6"R TP 2"solid + sealc.red
 Bfly 50 00 Cam 1PCA/Plast skid
 2-Plt XL:XL
 w/print "45326"

Schuetz Container Systems Inc.
 200 Aspen Hill Road
 NORTH BRANCH NJ 08876
 USA

Article-No. 4052749

Date Jul 15, 2025
 Page 2 / 4

Grid	Steel, galvanized
Bottom plate	Steel, galvanized
Corner protector	black
Label plate	extra large - 8 field, with Schütz-Ticket
additional label plate	backside extra large - 8 field

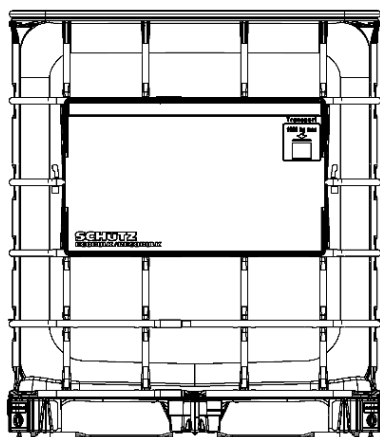
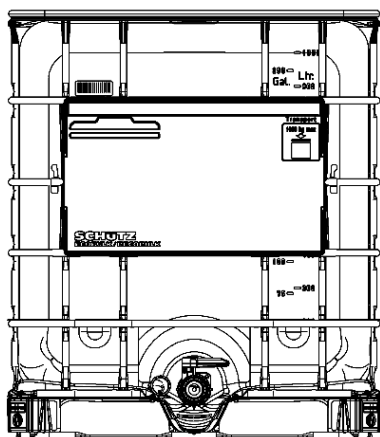

Inner container

Rectangular blow molded tank of high density polyethylene
 Container PE-HD, natural

Filling opening

Screw cap DN150 / 6", PE-HD, red
 O-ring gasket TPE
 Sealing-cap red



Packaging - Specification ECOBULK

SCHÜTZ

Transportcontainer ECOBULK 275 gal.
MX275 UN Nat/6"R TP 2"solid + sealc.red
Bfly 50 00 Cam 1PCA/Plast skid
2-Plt XL:XL
w/print "45326"

Schuetz Container Systems Inc.
200 Aspen Hill Road
NORTH BRANCH NJ 08876
USA

Article-No. 4052749

Date Jul 15, 2025
Page 3 / 4

Plug G2"plug closed

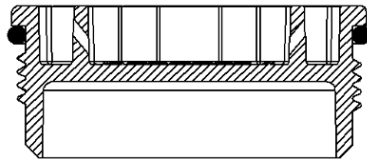

Discharge opening

Outlet valve	integr.butterfly-valve DN50/2"
Case	PE-HD
Connection thread	Camlok
Flap gasket / Ball gasket	PP
Handle color	blue, Handle protection
Screw cap	PE-HD
Screw cap gasket	PE, foamed
Screw cap color	natural
Outlet nozzle	without nozzle

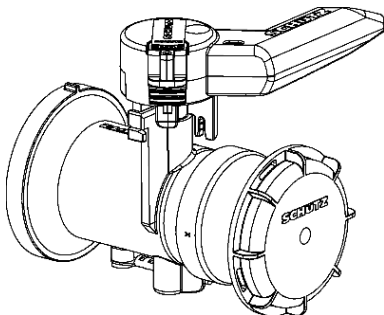

Features

w/Print

UN-Marking

UN31HA1/Y/MM YY/USA/+AA2572/-3671/2033/1040L/60KG/100KPA SCHUETZ#

Heavy metals

Concentration level of heavy metals (Pb, Cd, Cr VI and Hg) in packaging does not exceed 100 ppm

Delivery

Ready for filling. The customer or filler is responsible for testing the material compatibility of the filling material with the packaging

This specification is manufactured and delivered in accordance with the current status of the SCHÜTZ "Quality Management Standard for Supplies of Packaging Materials", which you can view at the following link:
www.schuetz.net/qmstandard

The maximum filling temperature depends on the respective filling product (specific heat capacity), but must not exceed 70° C (158° F) for HDPE packaging and 60° C (140° F) for LDPE packaging with an integrated inliner. Deformation such as sink and marks or wrinkling around edges and corners can be caused by temperature and

Packaging - Specification
ECOBULK



Transportcontainer ECOBULK 275 gal.
MX275 UN Nat/6"R TP 2"solid + sealc.red
Bfly 50 00 Cam 1PCA/Plast skid
2-Plt XL:XL
w/print "45326"

Schuetz Container Systems Inc.
200 Aspen Hill Road
NORTH BRANCH NJ 08876
USA

Article-No. **4052749**

Date Jul 15, 2025
Page 4 / 4

pressure differences during filling, transport, storage or depending on the vapour pressure of the filling product. To exclude these kinds of deformations, we recommend the use of an aeration and deaeration system suitable for the specific application.

The SCHÜTZ Technical Customer Service will be happy to recommend a suitable system for your application.

IBCs are designed and constructed for the transport, storage and handling of filling products in accordance with the relevant dangerous goods regulations.

During the use of the containers, especially in the case of multiple refilling cycles, the attachment parts such as outlet valves and screw caps as well as the associated gaskets are subject to varying degrees of wear, depending on the filling product, the type of application and the duration of use. The risk of wear increases with the frequency of use. In particular, washing procedures or improper handling during reconditioning can damage the IBC or its attachment parts. After the initial opening of the outlet valve, the container should be emptied as soon as possible and with as few intervals as possible and should be securely closed after each emptying operation.

Where IBCs are used in multiple refill cycles, it is the responsibility of the distributor and/or filler to carry out the necessary quality checks in accordance with applicable regulations and to ensure that the packaging is in a proper condition. Damaged components must be professionally repaired or replaced with original Schütz components or other approved components.

PLEASE NOTE:

The above statements are based on our current knowledge and experience. It does not exempt the user of our packaging from carrying out his own tests. No legally binding assurance can be derived from our information. It is the responsibility of the customer to comply with all applicable laws and regulations.

We would like to point out that in particular the legal transport obligations according to the Orange Book / IMDG / ADR / RID must be observed (Chapter 4.1.3.1 and also 49 CFR §173.24 (e) in the USA). It is therefore the responsibility of the filler or distributor to test the material compatibility of the filling product with the packaging and to evaluate the general suitability for the respective intended use.

Please note that for applications in EX-zones, the applicable contents of IEC TS 60079-32-1 and TRGS 727 must be observed, irrespective of the information given in the Material Safety Data Sheet (MSDS).